



UPPSALA
UNIVERSITET



Humble Materials & Transformative Play

Rebecca Rouse, PhD (Rebecca.Rouse@his.se)

Associate Professor of Media Arts, Aesthetics & Narration
Division of Game Development, School of Informatics
University of Skövde, Sweden

Nassim Parvin, PhD (Nassim@gatech.edu)

Associate Professor of Digital Media
School of Literature, Media, and Communication
Georgia Institute of Technology, USA

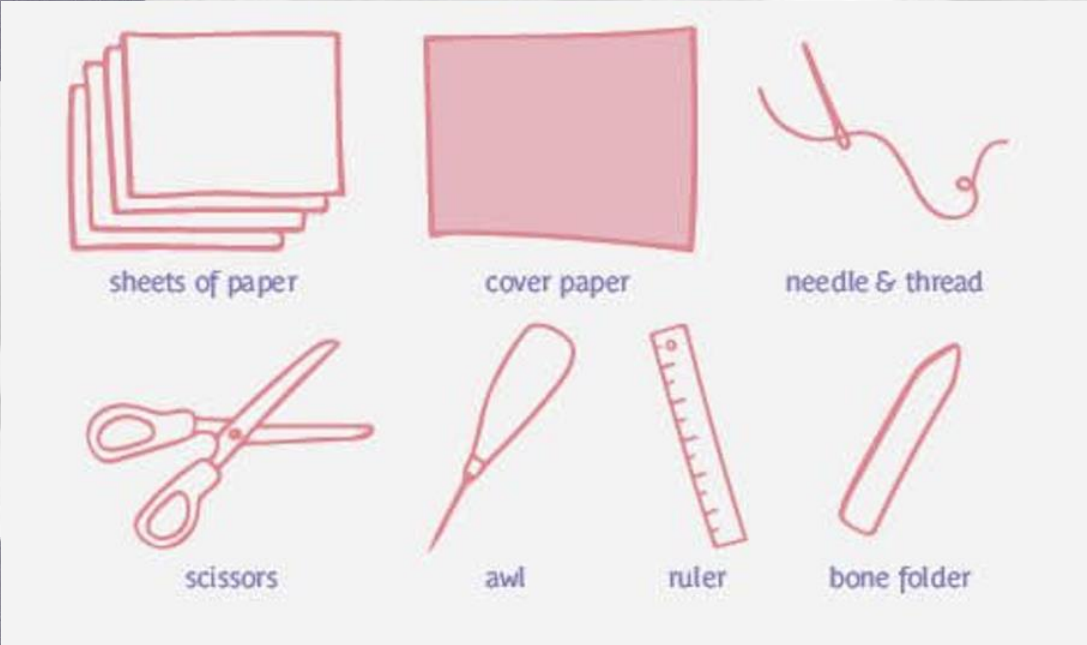

Feminist Philosophical Toys

Toy #1: Book Making



Scissors

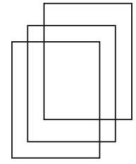

Sheets of Paper



Ruler



Cover Paper

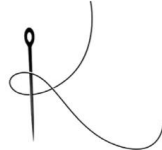

Needle & Thread



Awl

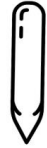

Bone Folder

Necessary

Optional

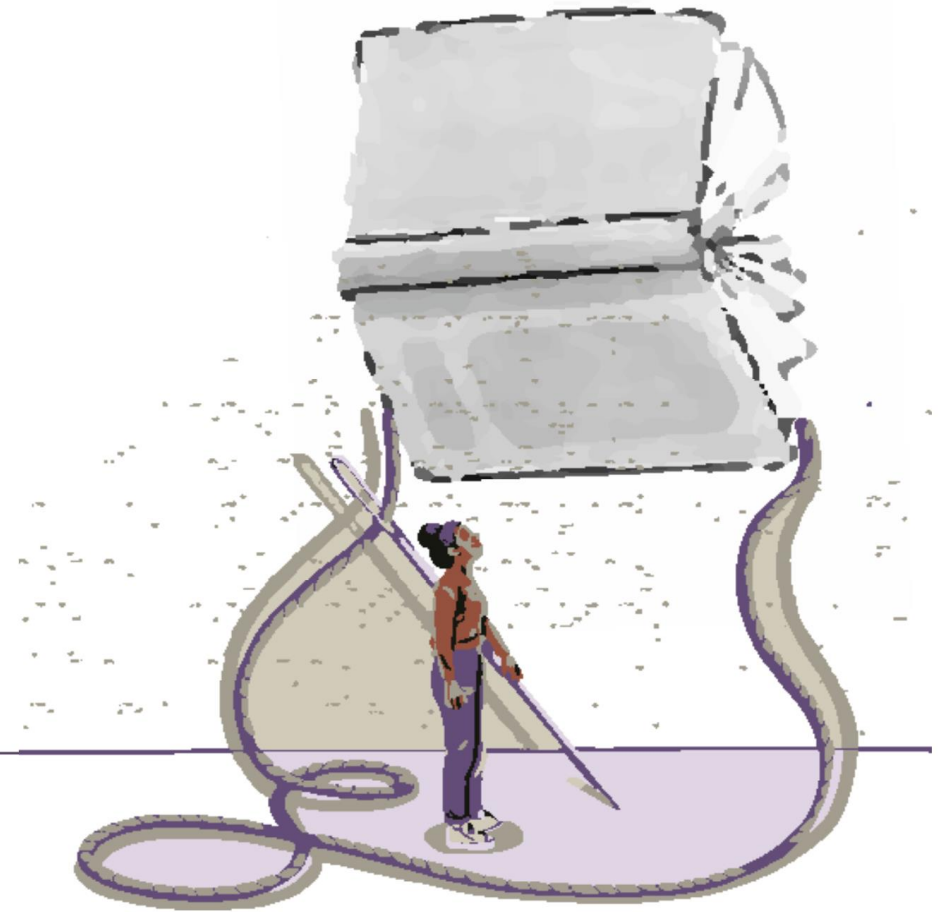
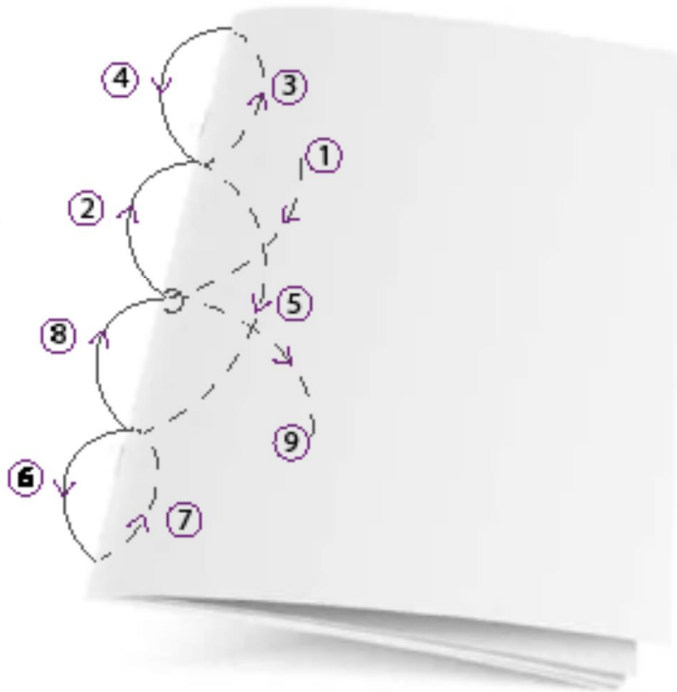

- Drucker, Johanna. 2004. *The Century of Artists' Books*. 2nd ed. New York: Granary Books.
- Fanni, Maryam, Matilda Flodmark, and Sara Kaaman, eds. 2020. *Natural Enemies of Books: A Messy History of Women in Printing and Typography*. N.p.: Occasional Papers.
- Liboiron, Max. 2020. "Exchanging." In *Transmissions: Critical Tactics for Making and Communicating Research*, edited by Kat Jungnickel, 89–107. Cambridge, MA: MIT Press.

Toy #1: Book Making

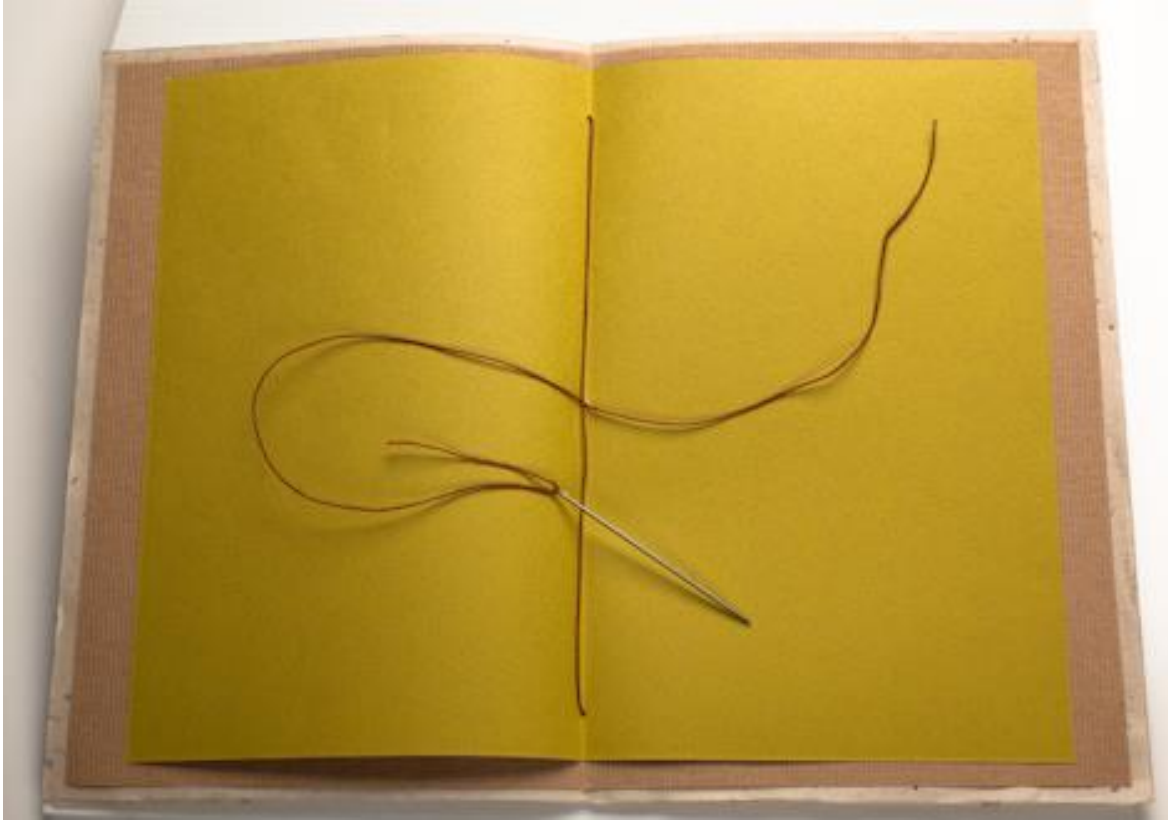

Toy #2: Oracle Cards

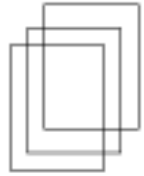

Sheets of
cardboards



Pen/Pencil

Necessary

cut your desired
piece of paper or
cardboard and
draw

Forsee a disaster

Write empowering
concepts and state-
ments

Example

You, the designer,
are the entity like-
ly to benefit most
meaningfully from
your design in spite
of your claims and/
or desires to help
others.

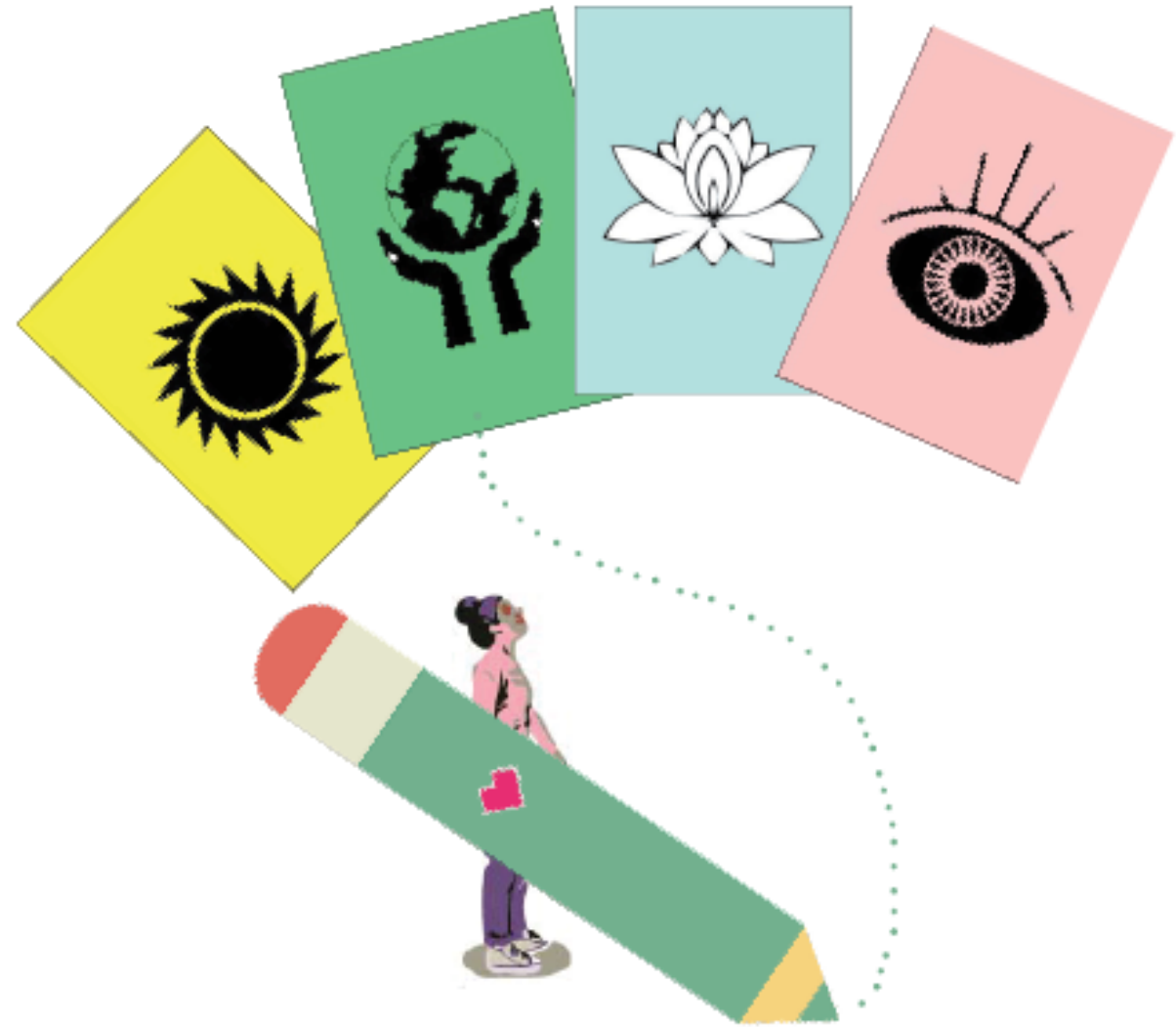

- Jasanoff, Sheila. 2016. The Ethics of Invention: Technology and the Human Future. WW. Norton and Company.
- Parvin, Nassim and Anne, Pollock. 2020. Unintended by Design: On the Political Uses of “Unintended Consequences.” Engaging Science, Technology and Society (6) 320-327.

Toy #2: Oracle Cards

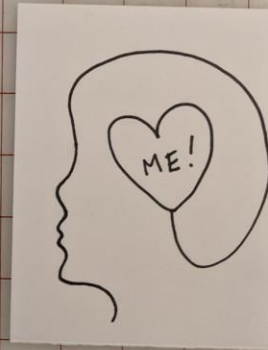
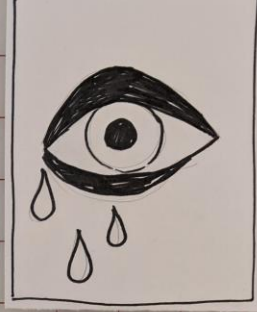

Your design makes a spectacle and/or commiserity of others' pain and sparks no justice or meaningful change that positively impacts those in pain.

Your design is completely inaccessible to one or more already underserved groups of people.

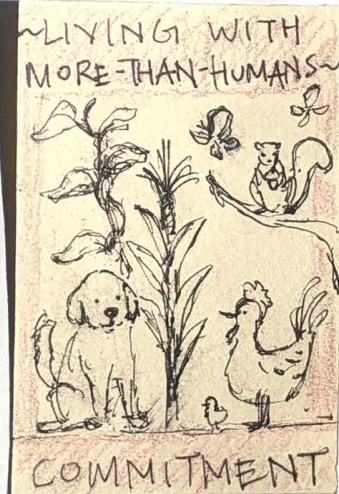

Your design empowers objects, systems, and/or corporations at the expense of, or instead of empowering people, animals, other living beings or ecosystems.

You, the designer, are the entity likely to benefit most meaningfully from your design in spite of your claims and/or desires to help others.

Toy #3: Experience Frames

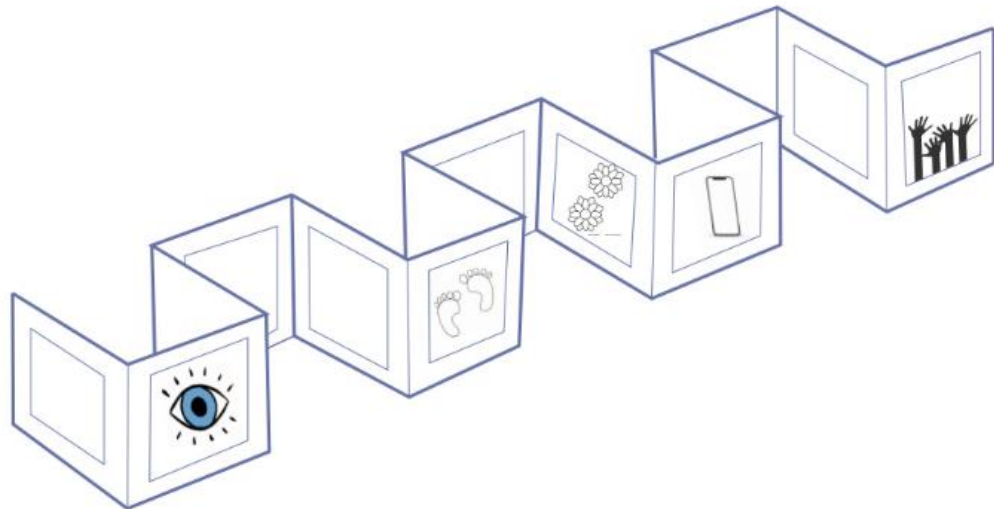
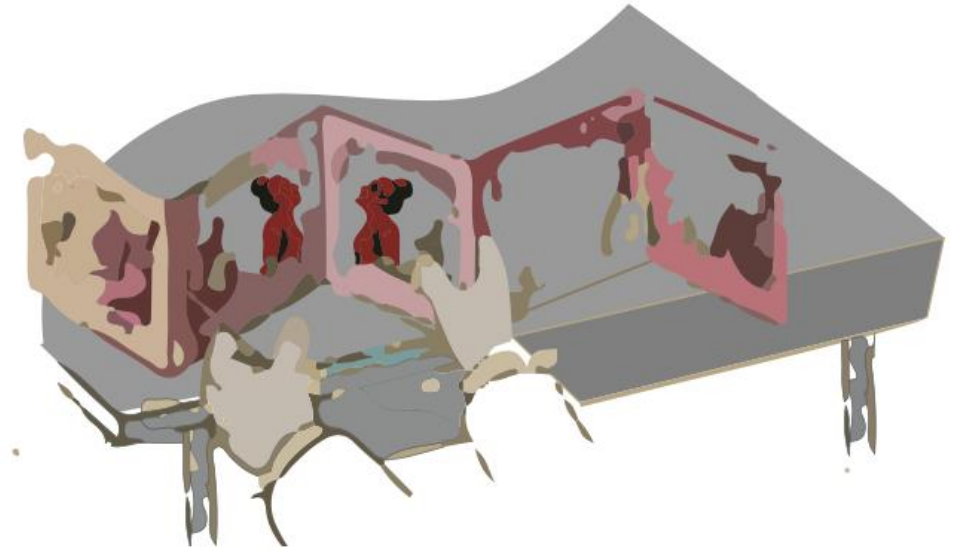
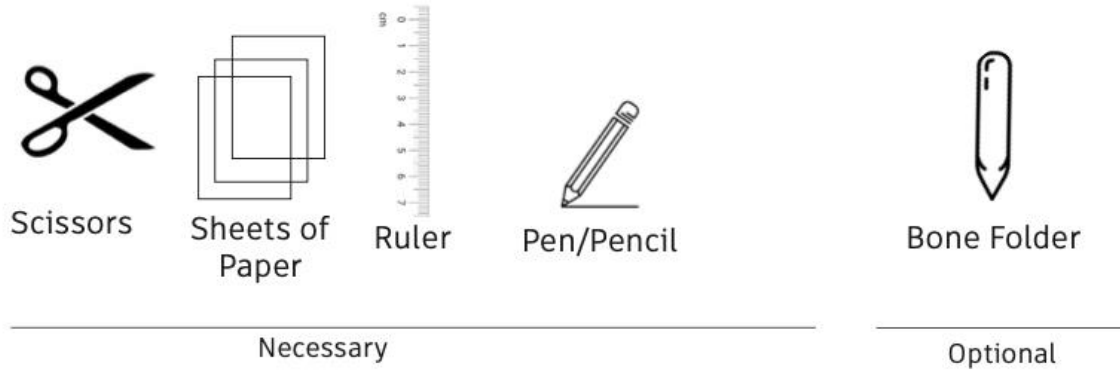

- Crenshaw, Kimberlé. 1990. "Mapping the Margins: Intersectionality, Identity Politics, and Violence against Women of Color." *Stanford Law Review* 43 (6): 1241–79.
- Harding, Sandra. 1992. "Rethinking Standpoint Epistemology: What Is 'Strong Objectivity?'" *The Centennial Review* 36 (3): 437–70.
- Takacs, David. 2003. "How Does Your Positionality Bias Your Epistemology?" *Thought & Action: The NEA Higher Education Journal* (Summer): 27–38.

Toy #3: Experience Frames

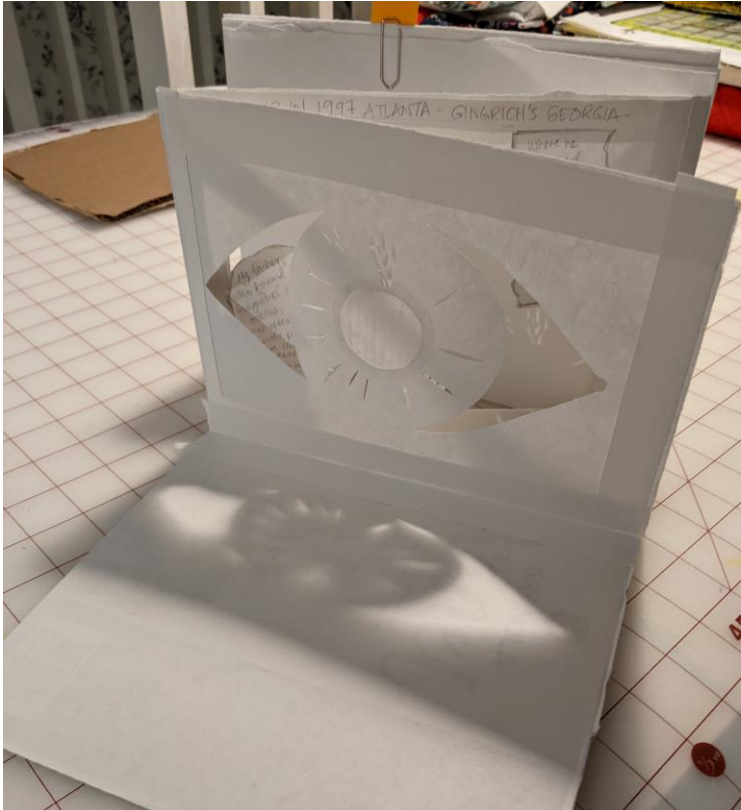
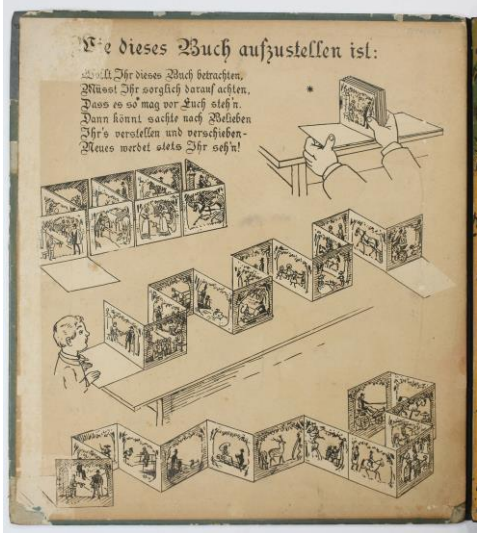
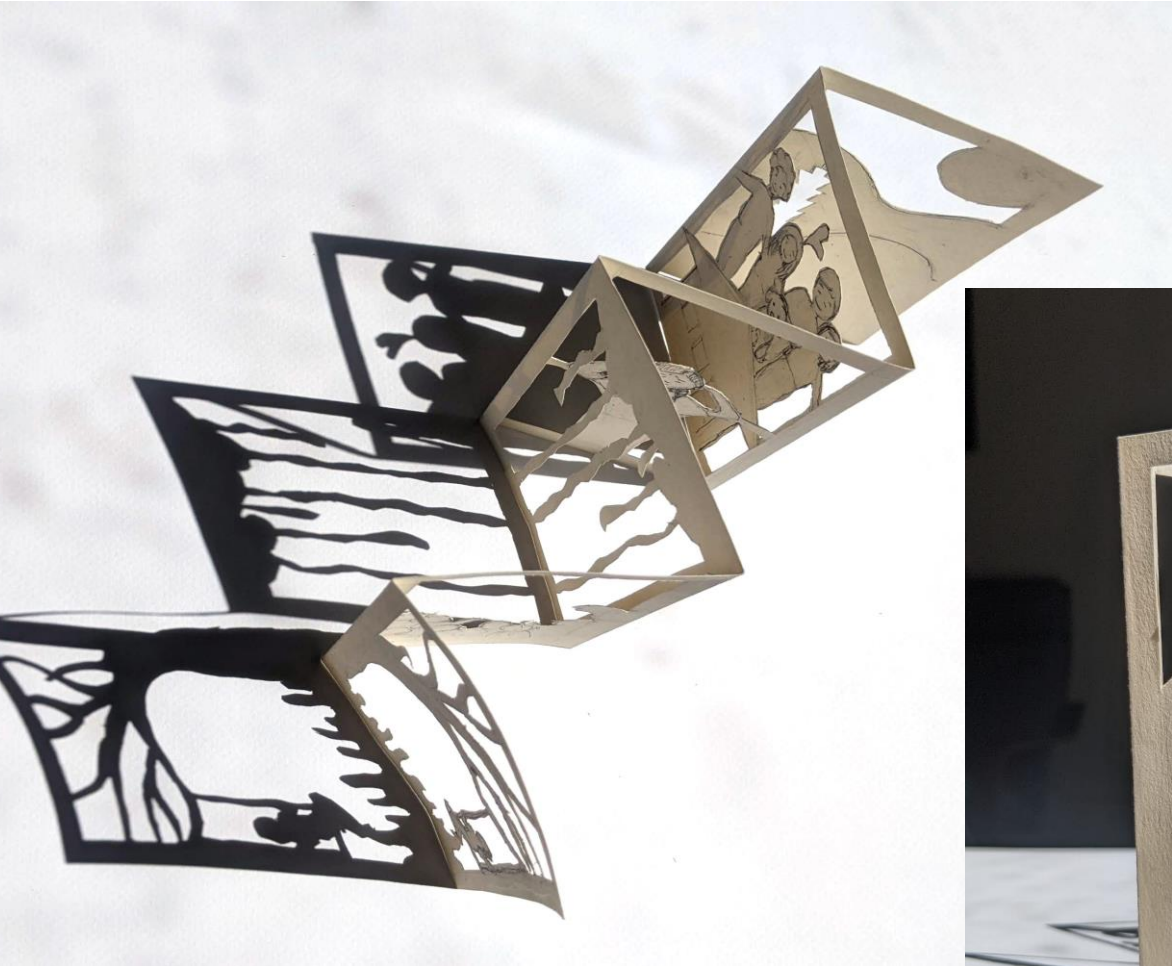

Toy #4: Circular Conversations

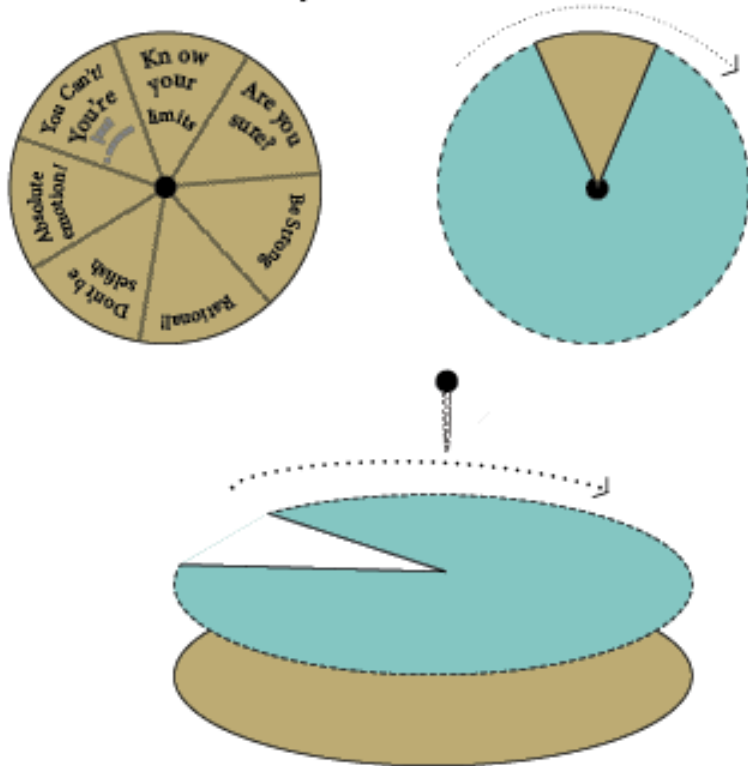
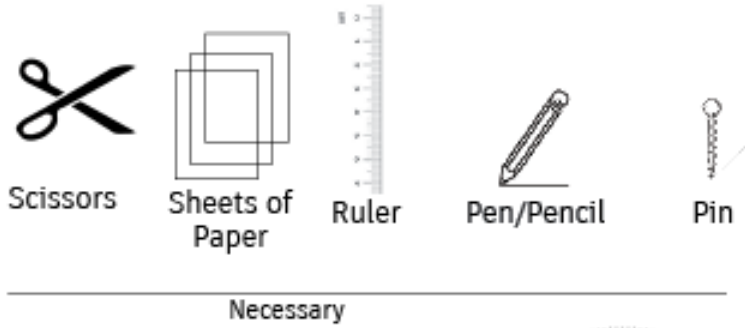

- Ahmed, Sara. 2021. *Complaint!* Durham, NC: Duke University Press.
- Boal, Augusto. 2006. *The Aesthetics of the Oppressed*. Translated by Adrian Jackson. London: Routledge.
- Harro, Bobbie. 2018. "The Cycle of Liberation." In *Readings for Diversity and Social Justice*, 4th ed., edited by Maurianne Adams, Warren J. Blumenfeld, D. Chase J. Catalano, Keri Dejong, Heather W. Hackman, Larrisa E. Hopkins, Barbara Love, Madeline L. Peters, Davey Shlasko, and Ximena Zuniga, 627–34. New York: Routledge.

Toy #4: Circular Conversations

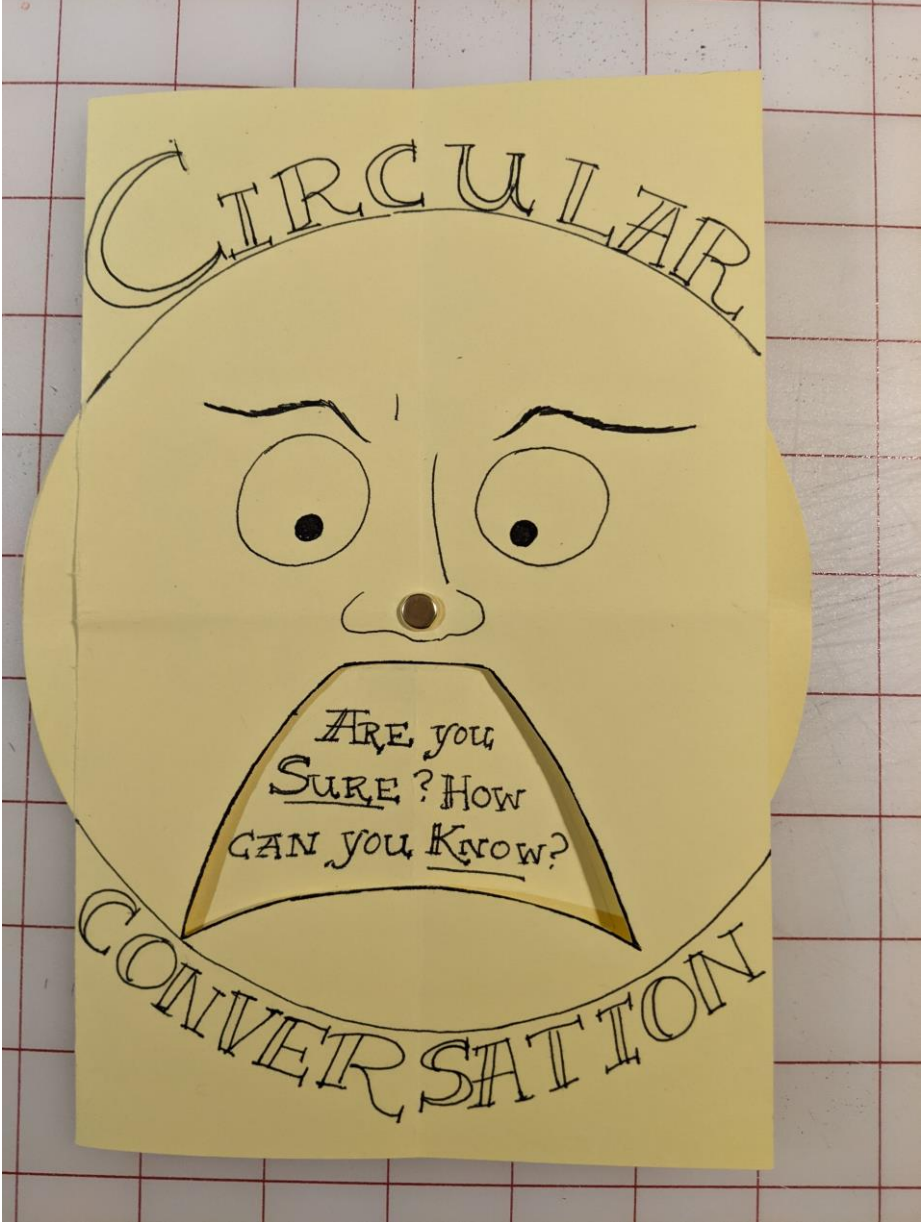
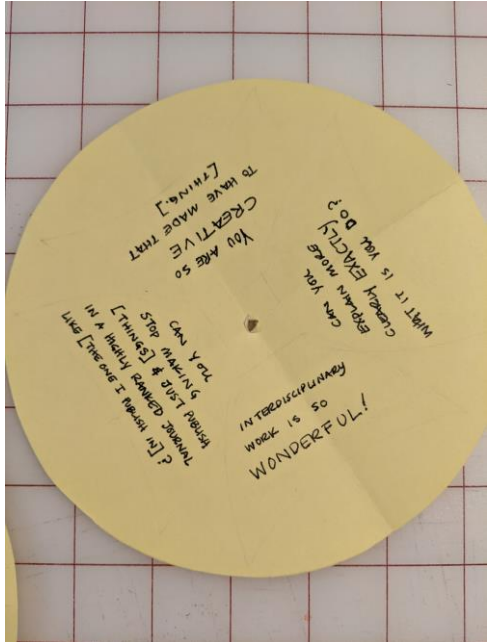
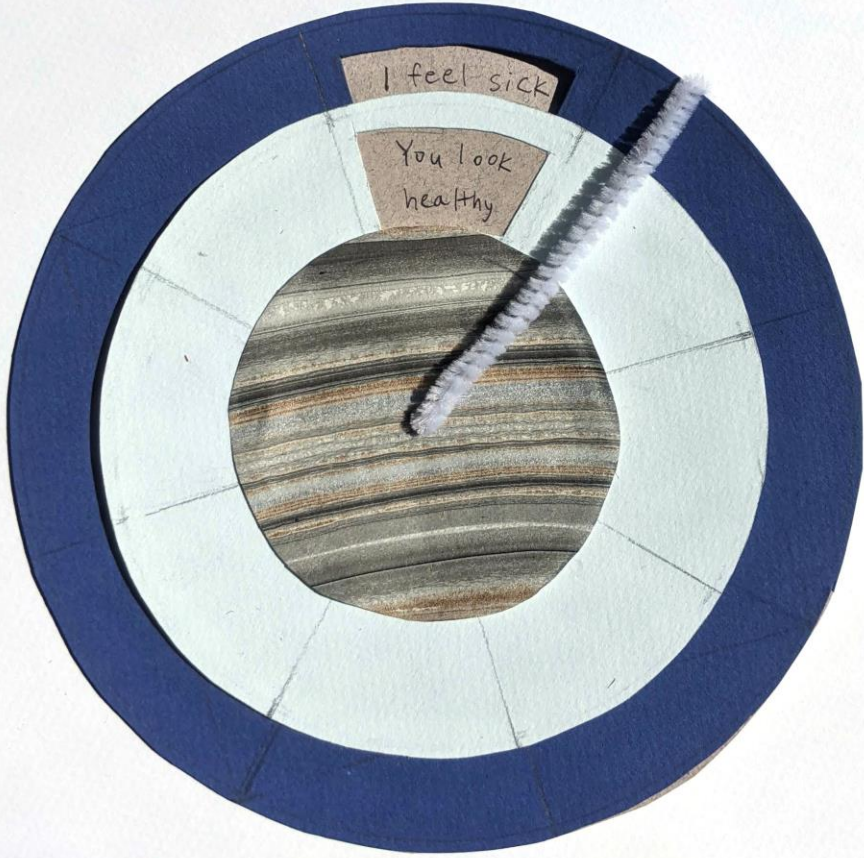

Toy #5: Conflicts & Coalitions Accordion

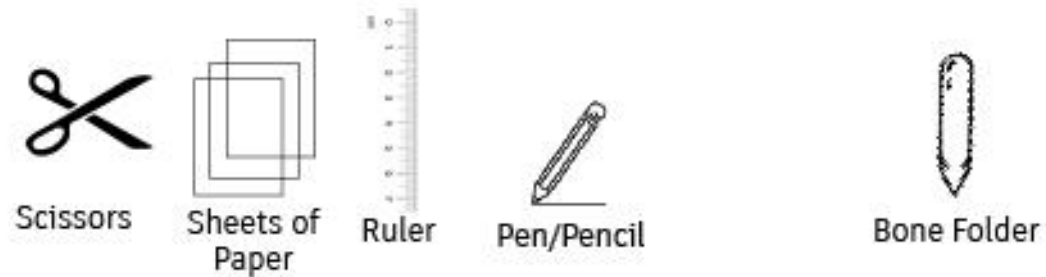

Necessary

Optional

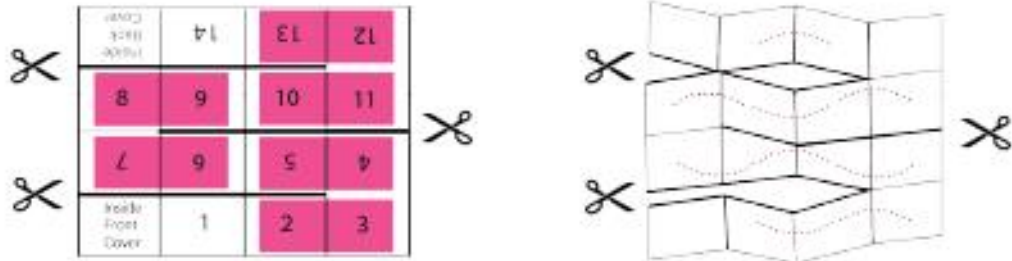

- Mouffe, Chantal. 2013. *Agonistics: Thinking the World Politically*. London: Verso Books.
- hooks, bell. 2010. *Teaching for Critical Thinking: Practical Wisdom*. New York: Routledge.
- Jones, Susan R. 2008. "Student Resistance to Cross-Cultural Engagement: Annoying Distraction or Site for Transformative Learning?" In *Creating Inclusive Campus Environments for Cross-Cultural Learning and Student Engagement*, edited by Shaun R. Harper, 67–85. N.p.: National Association of Student Personnel Administrators.

Toy #5: Conflicts & Coalitions Accordion

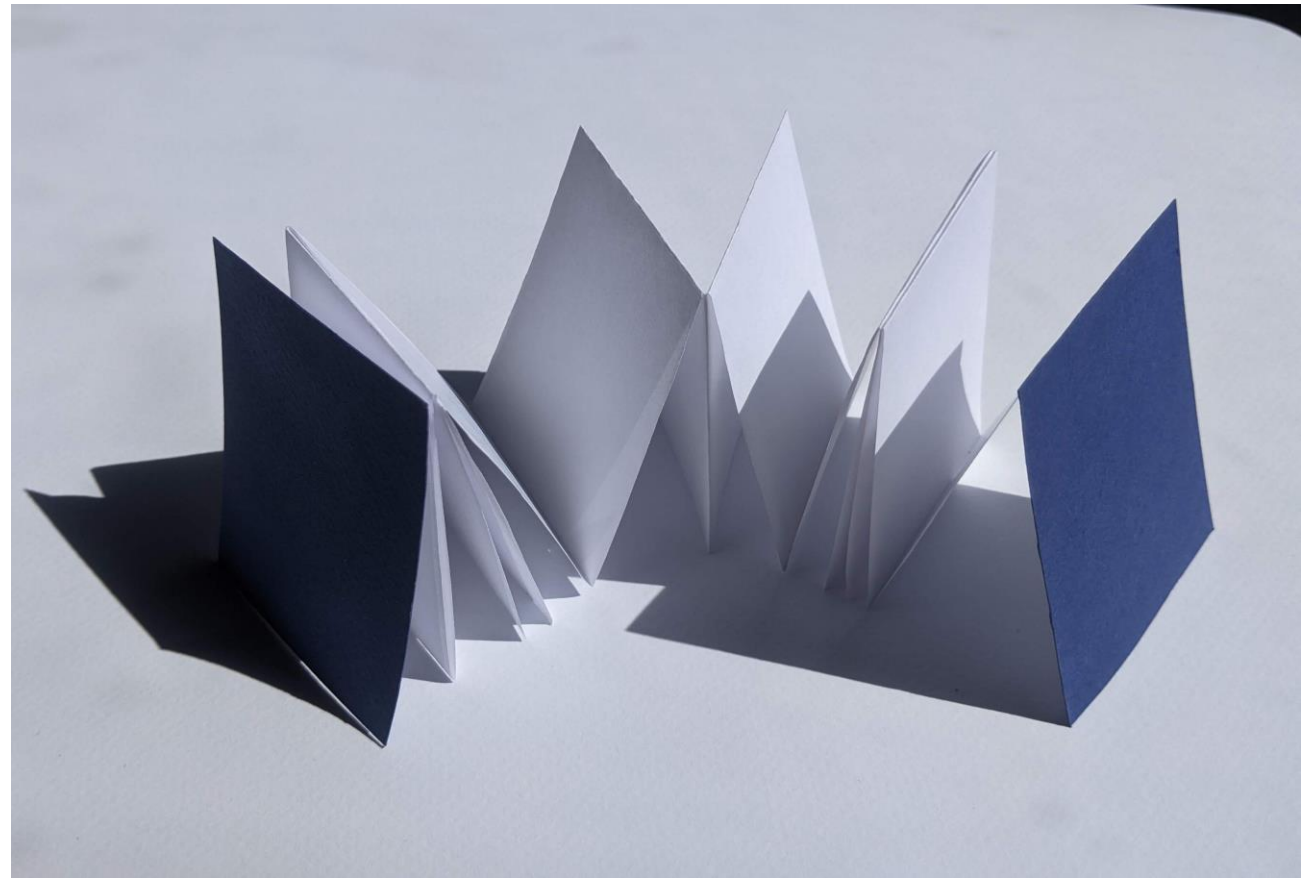
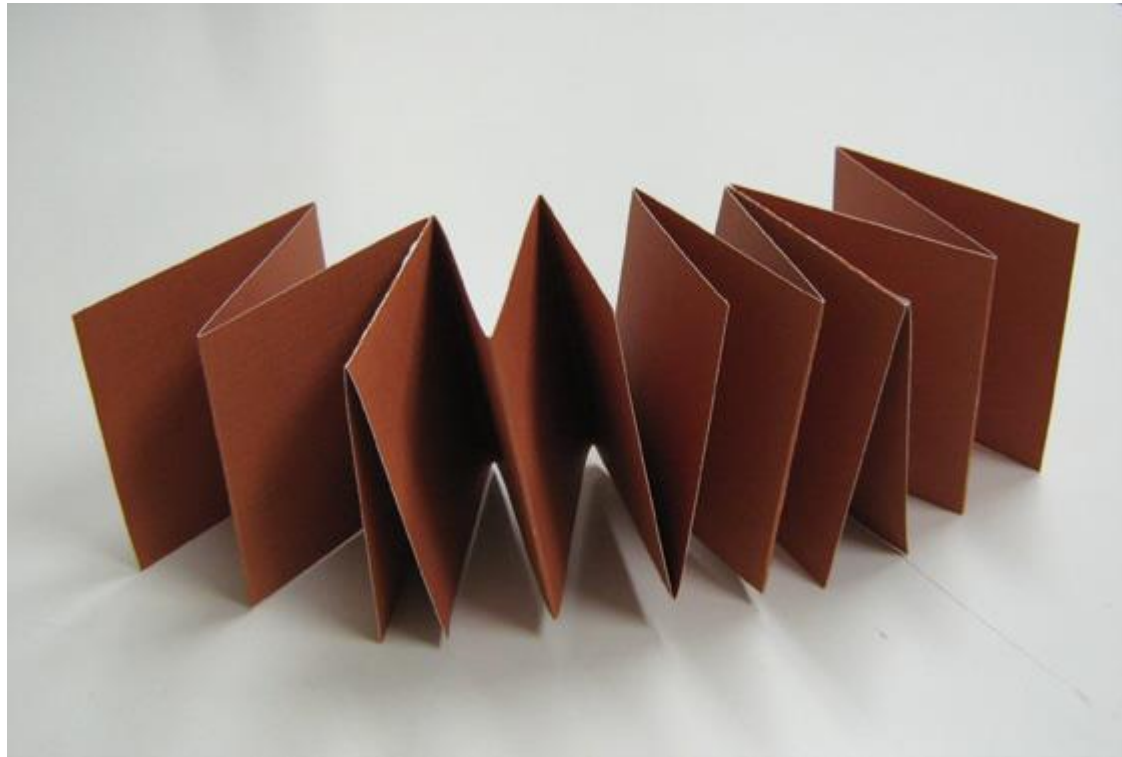

Toy #6: Fortune Teller



Scissors

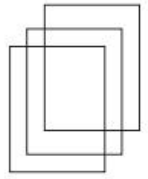

Sheets of Paper



Ruler



Pen/Pencil

Necessary



1

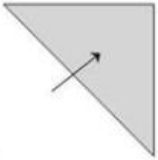

2

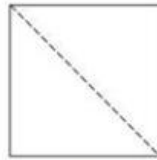

3

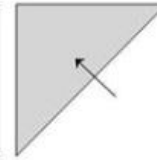

4

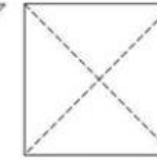

5

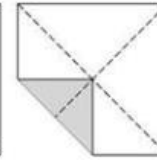

6



7

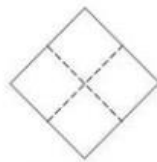

8

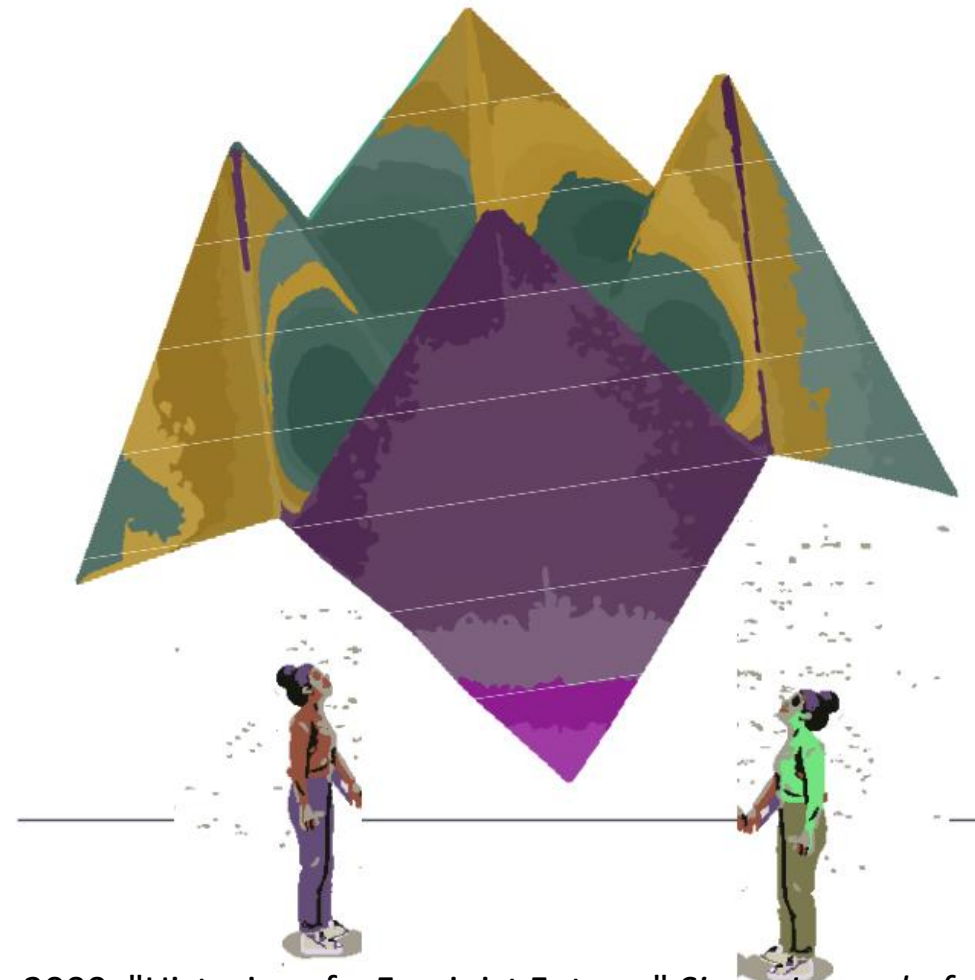
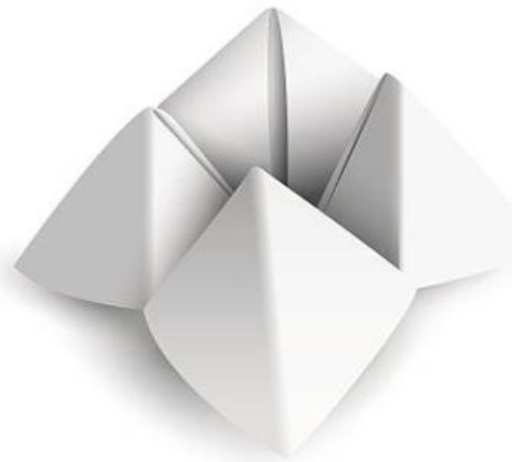

- Grosz, Elizabeth. 2000. "Histories of a Feminist Future." *Signs: Journal of Women in Culture and Society* 25 (4): 1017–21.
- Martins, Luiza Prado de O. 2014. "Privilege and Oppression: Towards a Feminist Speculative Design." In *Design's Big Debates - DRS International Conference 2014, June 16–19 2014*.
- LeGuin, Ursula K. 2019. *The Carrier Bag Theory of Fiction*. London: Ignota Books.

Toy #6: Fortune Teller

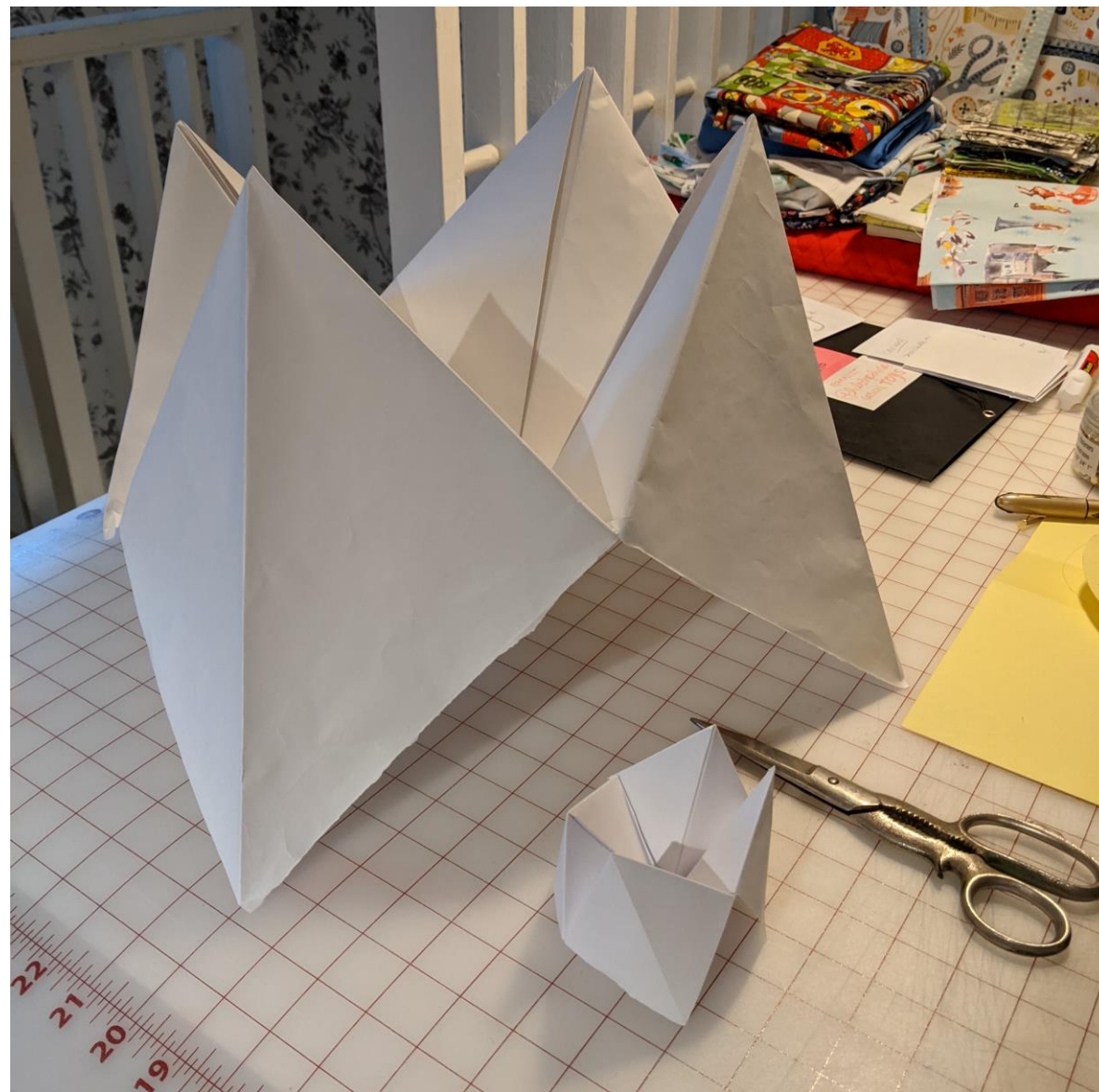

Toy #7: Curation & Collection Folio

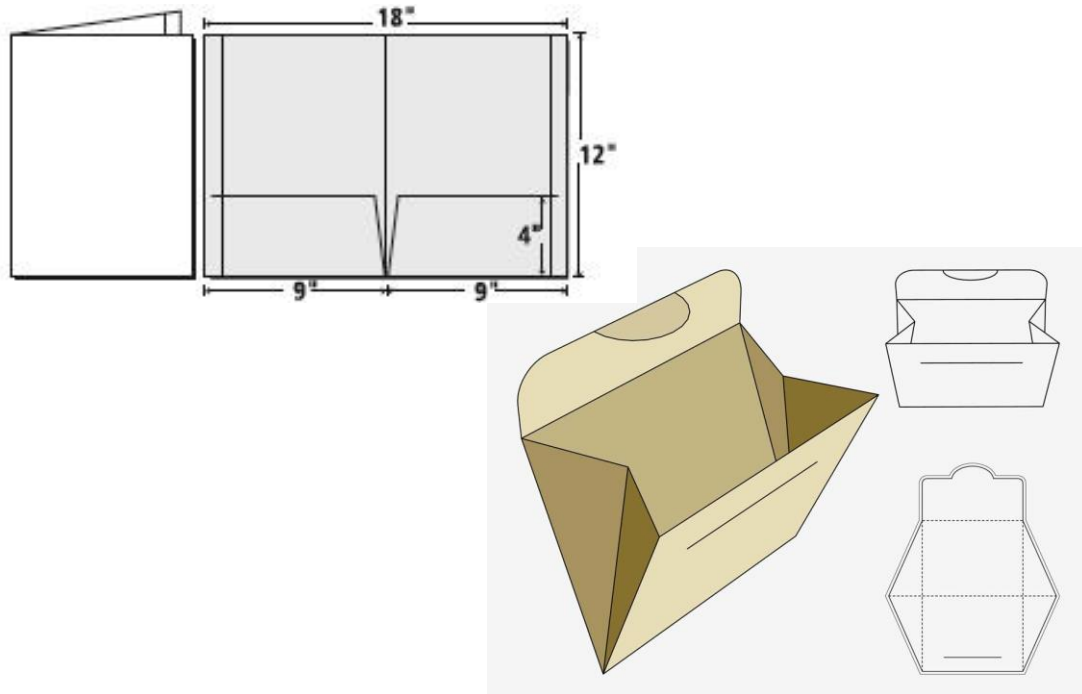

- Barad, Karen. 2007. *Meeting the Universe Halfway: Quantum Physics and the Entanglement of Matter and Meaning*. Durham, NC: Duke University Press.
- Mak, Bonnie, and Julia Pollack. 2020. "Cataloguing." In *Transmissions: Critical Tactics for Making and Communicating Research*, edited by Kat Jungnickel, 228–38. Cambridge, MA: MIT Press.
- Richter, Dorothee, Elke Krasny, and Lara Perry, eds. 2016. *Curating in Feminist Thought*. Special issue of *OnCurating* 29 (May).



Unfolding Practice (2016)
Arzu Mistry and Todd Elkin

Toy #8: The Living Toy



- Simmer, Robin Wall. 2013. *Braiding Sweetgrass*. Milkweed Editions.
- Kohn, Eduardo. 2013. *How Forests Think*. University of California Press.
- Baxter, Joan. 2017. *The Mill: Fifty Years of Pulp and Protest*. Pottersfield Press.



The Feminist Philosophical Playground

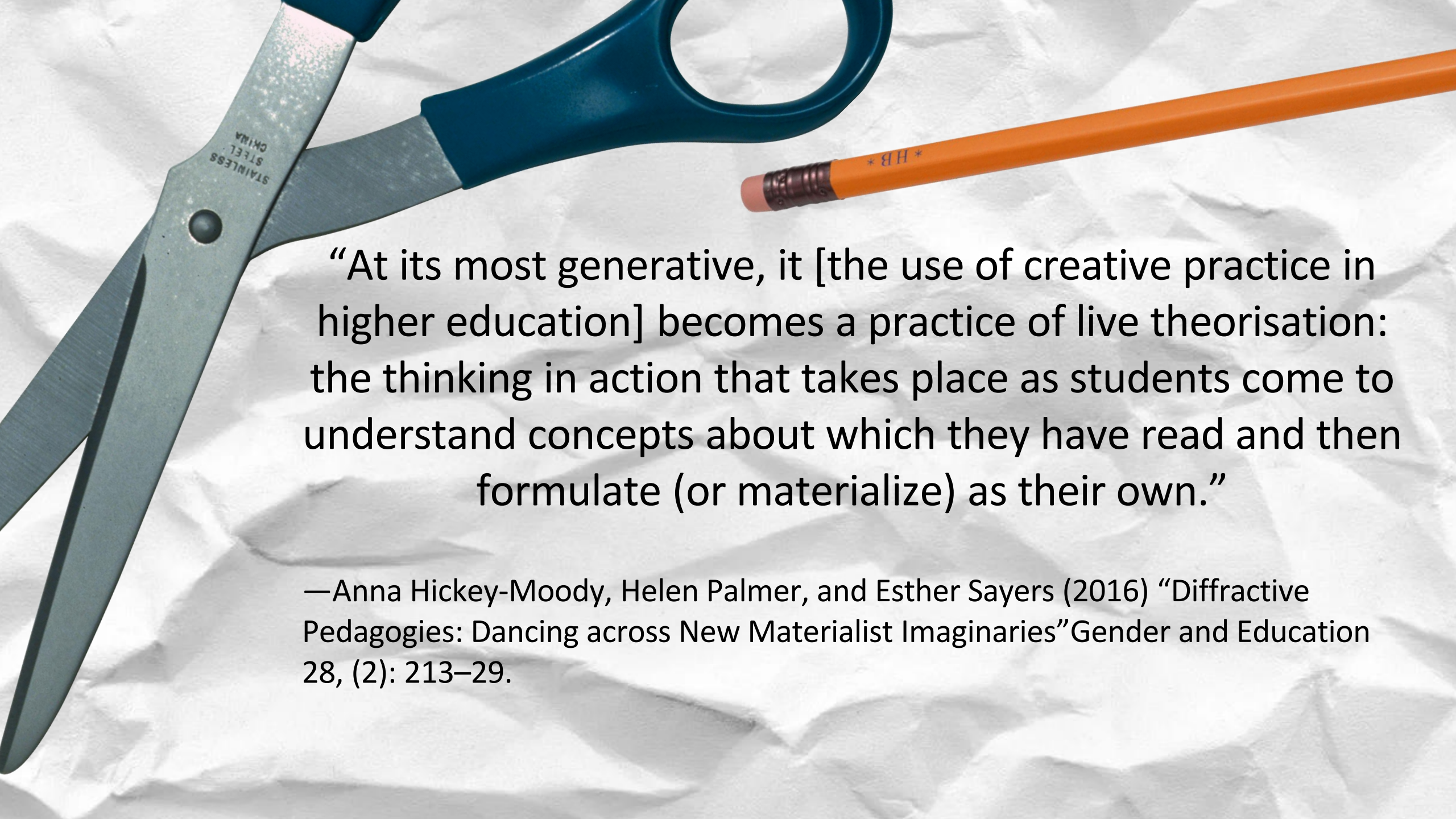

“At its most generative, it [the use of creative practice in higher education] becomes a practice of live theorisation: the thinking in action that takes place as students come to understand concepts about which they have read and then formulate (or materialize) as their own.”

—Anna Hickey-Moody, Helen Palmer, and Esther Sayers (2016) “Diffractive Pedagogies: Dancing across New Materialist Imaginaries” *Gender and Education* 28, (2): 213–29.